

SEEKING
LED-Lighting

HBD High Bay Light

160
LM/W

High Efficiency
160LM/W



4000K-6000K



IP65



CE

CB

✓ RoHS

Product Parameters

Item NO.	XJ-HBD100W-H/ XJ-HBD150W-H/ XJ-HBD200W-H / XJ-HBD240W-H
Brand of LED Chips	MTC (SMD 2835)
LED QTY.	308PCS(100W) / 420PCS(150W) 532PCS(200W) / 616PCS(240W)
Brand of LED Driver	SOSEN
Driver Type	Constant Current (CC)
Input Voltage & Frequency	100-305Vac 50/60Hz
Luminous Flux	38400LM /240W
LED Luminaire Efficacy	160±5%LM/W
Housing	Aluminum Alloy
Finish	Powder Coating
Fixture Color	Black
Optics	PC Optical Lens
IP Rating	IP65
Operating Temperature	-40-50°C
Lifetime(L80B20)	100000H
Beam Angle	60°, 90°, 120°
Certifications	TUV, CB, CE, ROHS, SAA
Warranty	5 Years

Test Report

Test:U:219.91V I:1.0732A P:233.74W PF:0.9904 Freq:49.99Hz Lamp Flux:37125.1x1 lm

DATA OF LAMP		PHOTOMETRIC DATA			
MODEL	2835	Eff: 158.83 lm/W			
NOMINAL POWER(W)	240	lmax(cd)	17427	S/MH(C0/180)	1.26
RATED VOLTAGE(V)	220	LOR(%)	100.0	S/MH(C90/270)	1.26
NOMINAL FLUX(lm)	37125.1	TOTAL FLUX(lm)	37125	hUP, DN(C0-180)	1.6,47.4
LAMPS INSIDE	1	CIE CLASS	DIRECT	hUP, DN(C180-360)	1.7,49.2
TEST VOLTAGE(V)	230	hup(%)	3.4	CIBSE SHR NOM	1.25
		hdown(%)	96.6	CIBSE SHR MAX	1.30

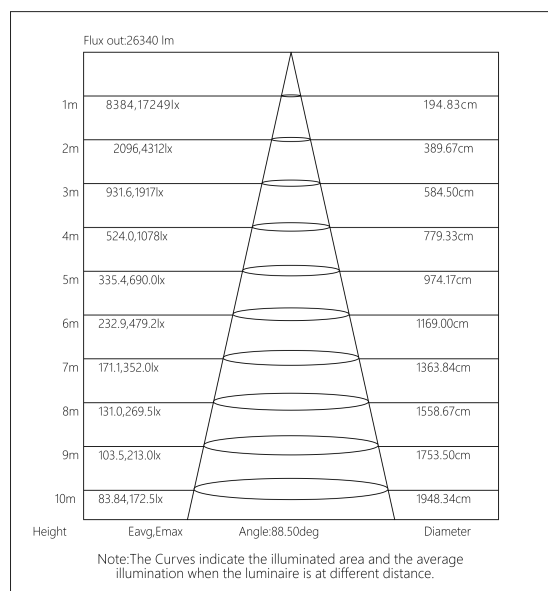
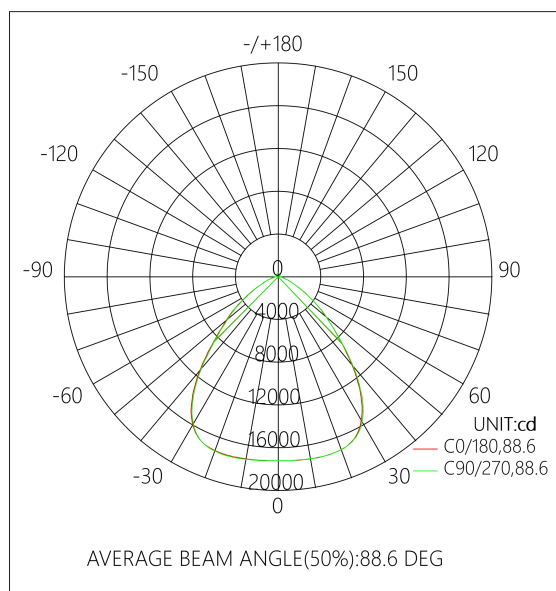

Dimension

Unit: mm

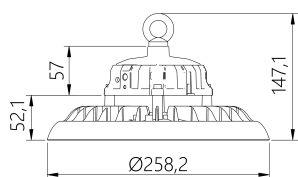

XJ-HBD100W-H

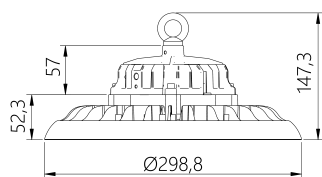

XJ-HBD150W-H

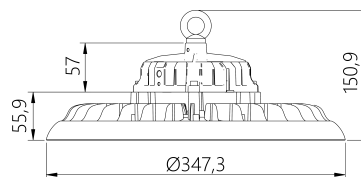

XJ-HBD200W-H

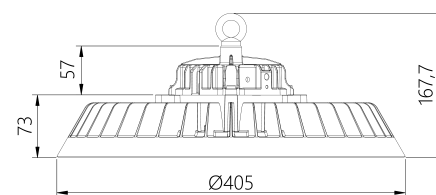

XJ-HBD240W-H

Photometry

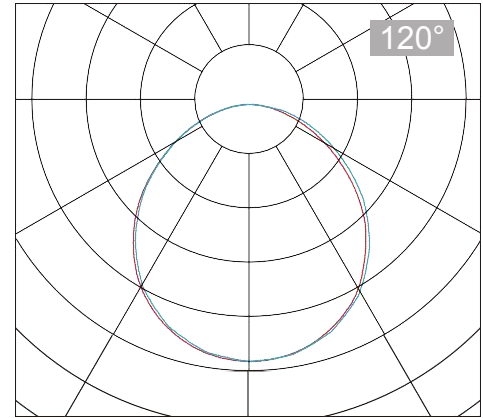
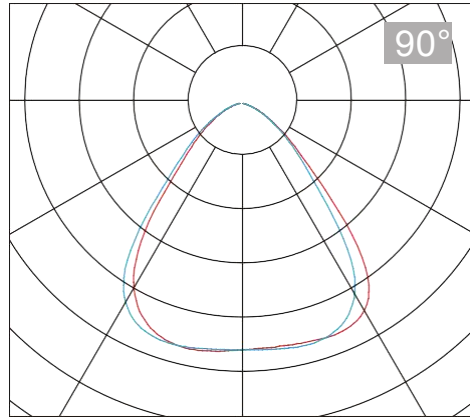
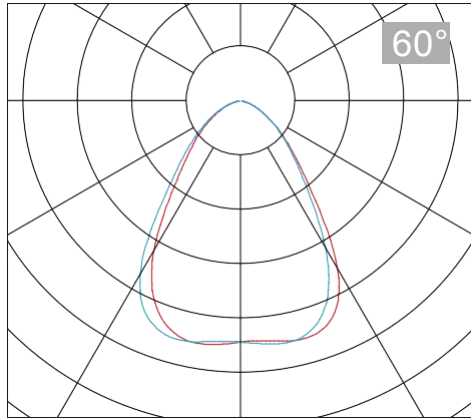

Split Graph

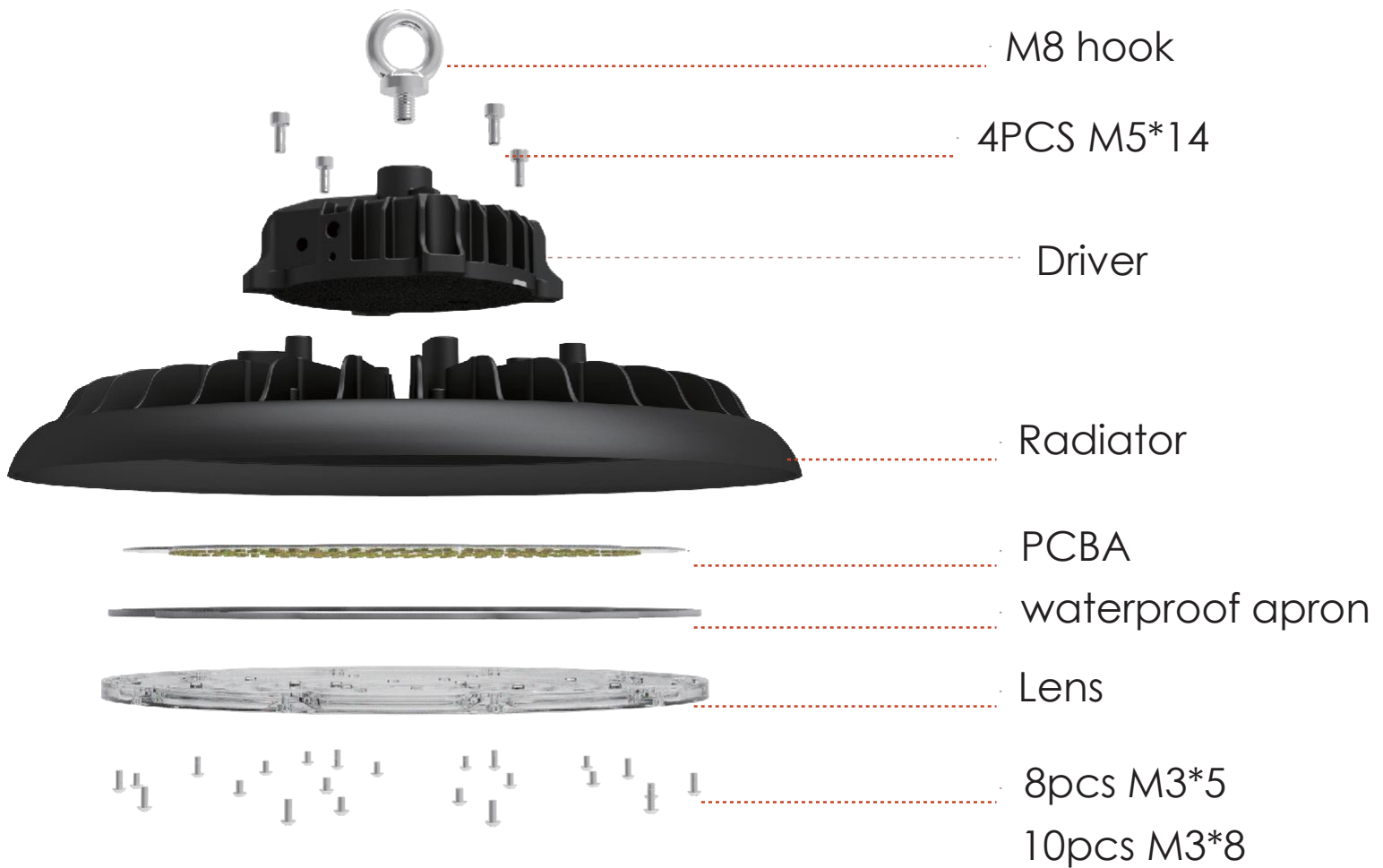

Packing

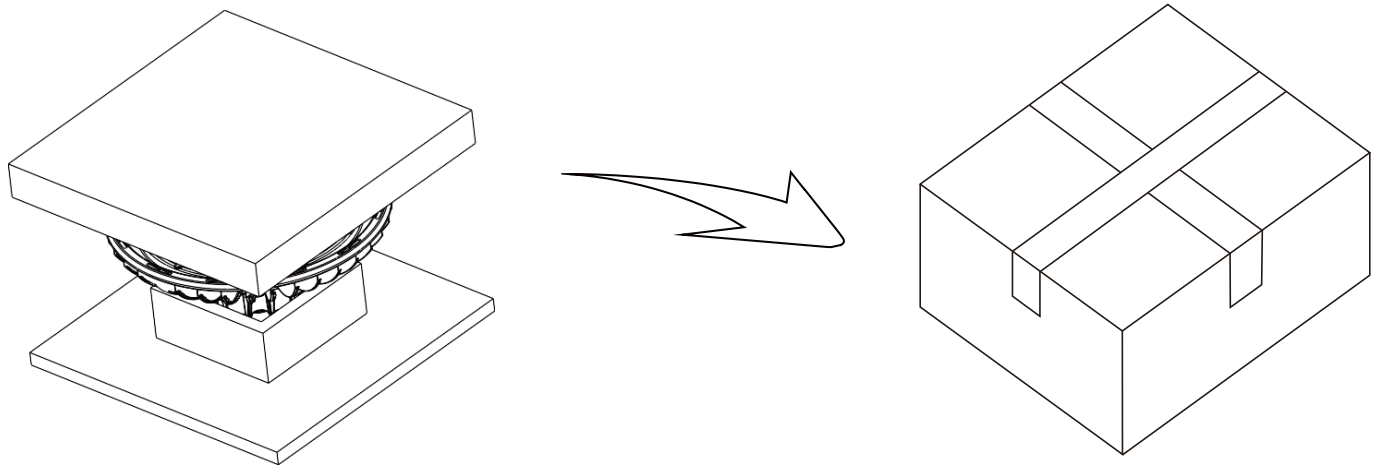

Model	N.W.	G.W.	Carton Size
XJ-HBD100W-H	2.0Kg	2.3Kg	31.2x31.2x17.5cm
XJ-HBD150W-H	2.6Kg	3.0Kg	33.8x33.8x18.0cm
XJ-HBD200W-H	2.9Kg	3.8Kg	39.8x39.8x18.5cm
XJ-HBD240W-H	3.6Kg	4.8Kg	45.6x45.6x20.5cm

Note

Input voltage AC100-305V, Please power off when installation to prevent electric shock. Product IP65 waterproof level, don't used in high temperature place.

When the temperature is too high, Over-temperature control circuitry activates, Output will be cut off, and the lamp will light off for a few minutes, After lowering temperature will be back to normal.

Warranty

Our company's products are used in constant current power supply, the whole lamp warranty for five year, one month replacement.

Remark:The warranty on the base of right storing way, right installing way, right using way, right maintaining way. Any broken out of our rule, out of our warranty. During the warranty time, we can choose repairing, replacing parts or replacing the whole products according the detail information. And we'll charge the customers some material fee and labor cost if the product out of our warranty time.

Product Applications



Factory



Indoor Square



Parking Lot



Supermarket



Warehouse



Workshop